



PNOZ s9

► Safety relays

PILZ
THE SPIRIT OF SAFETY

This document is the original document.

All rights to this documentation are reserved by Pilz GmbH & Co. KG. Copies may be made for the user's internal purposes. Suggestions and comments for improving this documentation will be gratefully received.

Source code from third-party manufacturers or open source software has been used for some components. The relevant licence information is available on the Internet on the Pilz homepage.

Pilz®, PIT®, PMI®, PNOZ®, Primo®, PSEN®, PSS®, PVIS®, SafetyBUS p®, SafetyEYE®, SafetyNET p®, the spirit of safety® are registered and protected trademarks of Pilz GmbH & Co. KG in some countries.



SD means Secure Digital

Introduction	5
Validity of documentation	5
Using the documentation	5
Definition of symbols	5
Safety	6
Intended use	6
Safety regulations	7
Safety assessment	7
Use of qualified personnel	7
Warranty and liability	7
Disposal	8
For your safety	8
Unit features	8
Safety features	8
Block diagram/terminal configuration	9
Function description	9
Timing diagrams	10
Delay-on de-energisation, not retriggerable	10
Delay-on de-energisation, retriggerable	11
Pulse on switching on	12
Delay-on energisation	13
Installation	13
Wiring	14
Preparing for operation	14
Operating modes and delay time	14
Set operating modes	15
Set delay time	15
Connection	15
Operation	17
Status indicators	18
Fault indicators	18
Faults - malfunctions	19
Dimensions in mm	19
Technical details	20
Safety characteristic data	25

Supplementary data	26
Service life graph	26
Permitted operating height	28
Remove plug-in terminals	29
Order reference	29
EC declaration of conformity	29

Introduction

Validity of documentation

This documentation is valid for the product PNOZ s9. It is valid until new documentation is published.

This operating manual explains the function and operation, describes the installation and provides guidelines on how to connect the product.

Using the documentation

This document is intended for instruction. Only install and commission the product if you have read and understood this document. The document should be retained for future reference.

Definition of symbols

Information that is particularly important is identified as follows:



DANGER!

This warning must be heeded! It warns of a hazardous situation that poses an immediate threat of serious injury and death and indicates preventive measures that can be taken.



WARNING!

This warning must be heeded! It warns of a hazardous situation that could lead to serious injury and death and indicates preventive measures that can be taken.



CAUTION!

This refers to a hazard that can lead to a less serious or minor injury plus material damage, and also provides information on preventive measures that can be taken.



NOTICE

This describes a situation in which the product or devices could be damaged and also provides information on preventive measures that can be taken. It also highlights areas within the text that are of particular importance.



INFORMATION

This gives advice on applications and provides information on special features.

Safety

Intended use

The unit meets the requirements of EN 60947-5-1, EN 60204-1 and VDE0113-1. In conjunction with a base unit the unit is used as a

- ▶ Contact expansion module to increase the number of contacts available on a base unit. Base units are all safety relays with feedback loop monitoring.
- ▶ Pulse relay
 - In accordance with EN ISO 12100 (inching circuit for limited movement of hazardous machine components during installation, set up and positioning)
 - In safety circuits in accordance with VDE 0113 and EN 60204-1 (e.g. on movable guards)
- ▶ Safe timer, delay-on energisation
 - In accordance with EN ISO 14119 (release with delay through timer)
 - In safety circuits in accordance with VDE 0113-1 and EN 60204-1 (e.g. on movable guards)
- ▶ Safe timer, delay-on de-energisation
 - In safety circuits in accordance with VDE 0113-1 and EN 60204-1 (e.g. on movable guards)

The max. achievable safety level depends on the base unit. The expansion module may not exceed this. The safety-related characteristic values stated under [Safety-related characteristic data](#) [ 25] can only be achieved if the base unit also exhibits these values.

- ▶ The unit can also be used without a base unit as a pulse relay or safe timer.

The unit is designed for use with

- ▶ Safety relays in the series PNOZsigma, PNOZ X, PNOZelog, PNOZmulti
- ▶ Safety gate monitors from the PST series
- ▶ Two-hand relays from the PNOZsigma, P2HZ series

The following is deemed improper use in particular

- ▶ Any component, technical or electrical modification to the product,
- ▶ Use of the product outside the areas described in this manual,
- ▶ Use of the product outside the technical details (see [Technical details](#) [ 20]).

**NOTICE****EMC-compliant electrical installation**

The product is designed for use in an industrial environment. The product may cause interference if installed in other environments. If installed in other environments, measures should be taken to comply with the applicable standards and directives for the respective installation site with regard to interference.

Safety regulations**Safety assessment**

Before using a device it is necessary to perform a safety assessment in accordance with the Machinery Directive.

Functional safety is guaranteed for the product as a single component. However, this does not guarantee the functional safety of the overall plant/machine. In order to achieve the required safety level for the overall plant/machine, define the safety requirements for the plant/machine and then define how these must be implemented from a technical and organisational standpoint.

Use of qualified personnel

The products may only be assembled, installed, programmed, commissioned, operated, maintained and decommissioned by competent persons.

A competent person is a qualified and knowledgeable person who, because of their training, experience and current professional activity, has the specialist knowledge required. To be able to inspect, assess and operate devices, systems and machines, the person has to be informed of the state of the art and the applicable national, European and international laws, directives and standards.

It is the company's responsibility only to employ personnel who

- ▶ Are familiar with the basic regulations concerning health and safety / accident prevention,
- ▶ Have read and understood the information provided in the section entitled Safety
- ▶ Have a good knowledge of the generic and specialist standards applicable to the specific application.

Warranty and liability

All claims to warranty and liability will be rendered invalid if

- ▶ The product was used contrary to the purpose for which it is intended,
- ▶ Damage can be attributed to not having followed the guidelines in the manual,
- ▶ Operating personnel are not suitably qualified,
- ▶ Any type of modification has been made (e.g. exchanging components on the PCB boards, soldering work etc.).

Disposal

- ▶ In safety-related applications, please comply with the mission time T_M in the safety-related characteristic data.
- ▶ When decommissioning, please comply with local regulations regarding the disposal of electronic devices (e.g. Electrical and Electronic Equipment Act).

For your safety

The unit meets all the necessary conditions for safe operation. However, please note the following:

- ▶ Note for overvoltage category III: If voltages higher than low voltage (>50 VAC or >120 VDC) are present on the unit, connected control elements and sensors must have a rated insulation voltage of at least 250 V.

Unit features

- ▶ Positive-guided relay outputs, either instantaneous, delay-on de-energisation (also retriggerable), pulsing or delay-on energisation:
 - 3 safety contacts
 - 1 auxiliary contact
- ▶ Switch-on time, pulse time or delay-on de-energisation selectable with rotary switches
- ▶ LED indicator for:
 - Supply voltage
 - Input status, channel 1
 - Input status, channel 2
 - Switch status channel 1/2
 - Start circuit
 - Error
- ▶ Plug-in connection terminals (either spring-loaded terminal or screw terminal)
- ▶ See order reference for unit types

Safety features

The unit meets the following safety requirements:

- ▶ The unit monitors its own output contacts.
- ▶ The safety function remains effective in the case of a component failure.
- ▶ Earth fault in the feedback loop is detected.
- ▶ Earth fault in the input circuit:
The output relays de-energise and the safety contacts open.

Block diagram/terminal configuration

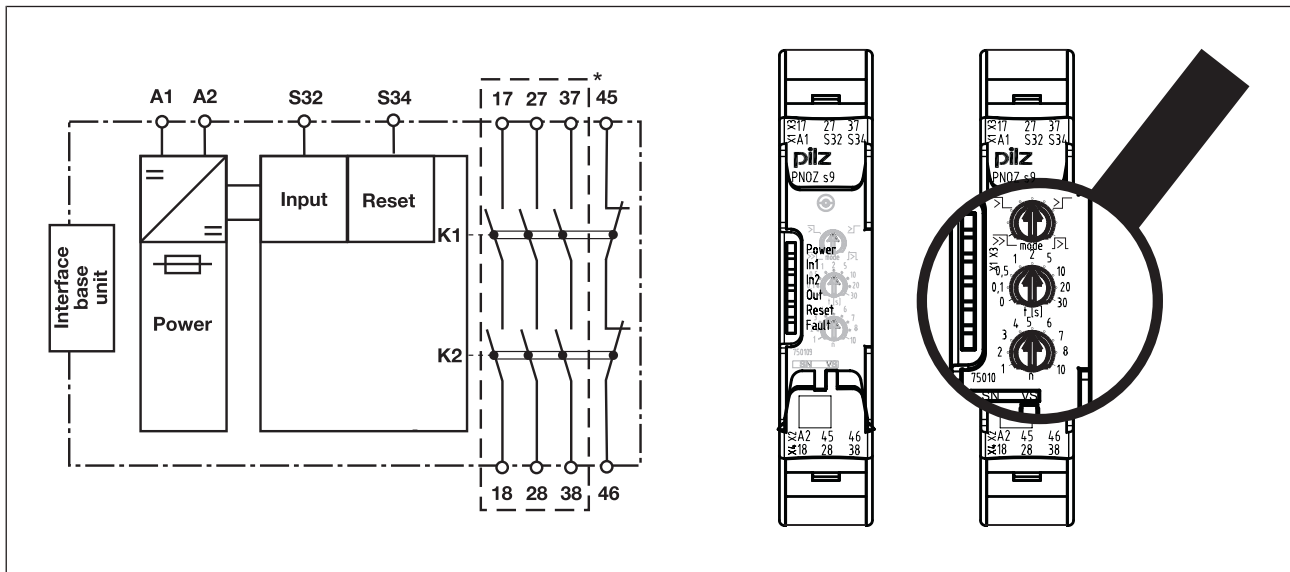





Fig.: Centre: Front view with cover, right: Front view without cover

*Safe separation from non-marked area in accordance with EN 60947-1, 6 kV, basic insulation between all safety contacts.

Function description

- ▶  Delay-on de-energisation, not retriggerable
If the supply voltage at the input circuit is interrupted, the safety contacts will open once the set release time has elapsed, even if the safety function is cancelled during the delay time. The unit cannot be reactivated until the delay time has elapsed.
- ▶  Delay-on de-energisation, retriggerable
(only possible as a standalone application or with the PNOZsigma base unit!)
If the supply voltage at the input circuit is interrupted, the safety contacts will open once the set release time has elapsed.
If the safety function is cancelled during the delay time (e.g. safety gate closed), the unit will remain active.
- ▶  Pulse on switching on
The safety contacts close when supply voltage is applied, the feedback loop is closed and finally the input circuit is closed. The safety contacts are reopened once the pulse time has elapsed.
If the input circuit is opened for more than 10 ms during the pulse time, the safety contacts will open immediately and the auxiliary contact will be closed.
- ▶  Delay-on energisation
The set delay time is started when supply voltage is applied, the feedback loop is closed and finally the input circuit is closed.
If the input circuit and feedback loop are closed once the delay time has elapsed, the safety contacts will close and the auxiliary contact will be opened.
If the input circuit is opened for more than 10 ms, the safety contacts will open immediately and the auxiliary contact will be closed.

with PNOZsigma base unit:

- ▶ Dual-channel operation via PNOZsigma connector

with other base units or without base unit:

- ▶ Single-channel operation: one input circuit affects the output relays

Timing diagrams

Delay-on de-energisation, not retriggerable

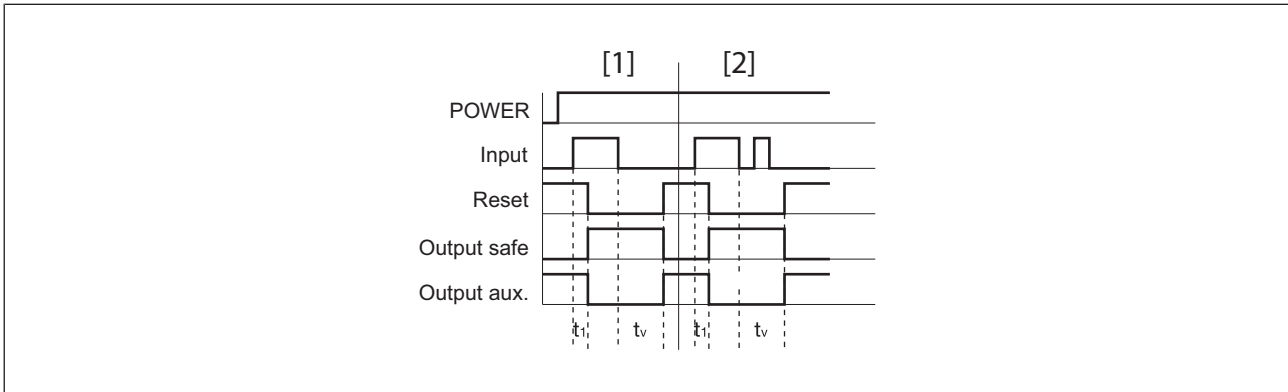

Legend

- ▶ POWER: Supply voltage
- ▶ Input: Input circuit
- ▶ Output safe: Safety contacts
- ▶ Output aux: Auxiliary contact
- ▶ Reset: Feedback loop input
- ▶ t_f : Switch-on delay
- ▶ t_v : Delay time
- ▶ [1]: Delay-on de-energisation with the time t_v
- ▶ [2]: No retriggering in the time t_v



NOTICE

At the latest the safety contacts open after the set delay time + 20 ms + 15% of the set value, even in the case of a component failure.

Delay-on de-energisation, retriggerable

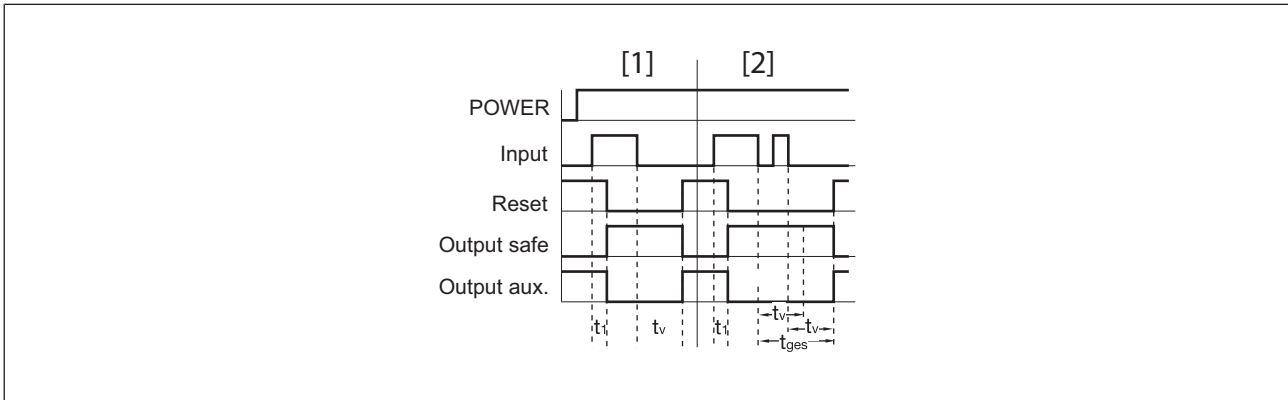

Legend

- ▶ POWER: Supply voltage
- ▶ Input: Input circuit
- ▶ Output safe: Safety contacts
- ▶ Output aux: Auxiliary contact
- ▶ Reset: Feedback loop input
- ▶ t_t : Switch-on delay
- ▶ t_v : Delay time
- ▶ t_{ges} : Overall delay time
- ▶ [1]: Delay-on de-energisation with the time t_v
- ▶ [2]: Retriggering in the time t_v for overall delay-on de-energisation t_{ges}



NOTICE

At the latest the safety contacts open after the set delay time + 20 ms + 15% of the set value, even in the case of a component failure.

Pulse on switching on

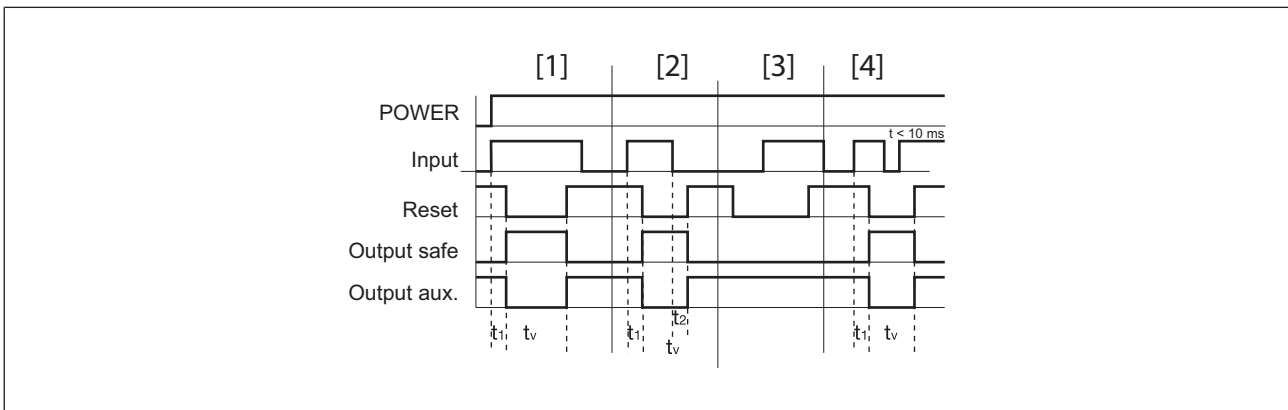

Legend

- ▶ POWER: Supply voltage
- ▶ Input: Input circuit
- ▶ Output safe: Safety contacts
- ▶ Output aux: Auxiliary contact
- ▶ Reset: Feedback loop input
- ▶ t_1 : Switch-on delay
- ▶ t_2 : Delay-on de-energisation
- ▶ t_v : Delay time (pulse time)
- ▶ [1]: Normal operating cycle
- ▶ [2]: Fault: Input circuit opened too early
- ▶ [3]: Fault: Feedback loop closed too late
- ▶ [4]: Normal operating cycle with supply interruption < 10 ms



NOTICE

At the latest the safety contacts open after the set delay time + 20 ms + 15% of the set value, even in the case of a component failure.

Delay-on energisation

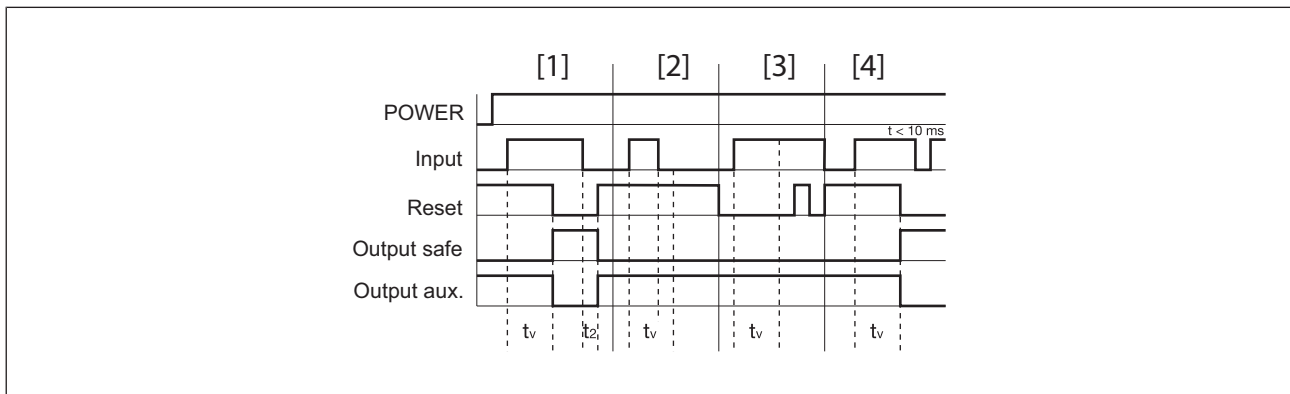

Legend

- ▶ POWER: Supply voltage
- ▶ Input: Input circuit
- ▶ Output safe: Safety contacts
- ▶ Output aux: Auxiliary contact
- ▶ Reset: Feedback loop input
- ▶ t_2 : Delay-on de-energisation
- ▶ t_v : Delay time
- ▶ [1]: Normal operating cycle
- ▶ [2]: Fault: Input circuit opened too early, before t_v expired
- ▶ [3]: Fault: Feedback loop closed too late after t_v elapsed
- ▶ [4]: Normal operating cycle with supply interruption < 10 ms



NOTICE

At the earliest the safety contacts close after the set delay time - 20 ms - 15% of the set value, even in the case of a component failure.

Installation

Install contact expansion module without base unit:

- ▶ Ensure that the plug terminator is inserted at the side of the unit.

Connect base unit and PNOZsigma contact expansion module:

- ▶ Remove the plug terminator at the side of the base unit and at the contact expander module
- ▶ Connect the base unit and the contact expansion module using the connector supplied, before mounting the units to the DIN rail.

Control cabinet installation

- ▶ The safety relay should be installed in a control cabinet with a protection type of at least IP54.
- ▶ Use the notch on the rear of the unit to attach it to a DIN rail (35 mm).

- ▶ When installed vertically: Secure the unit by using a fixing element (e.g. retaining bracket or end angle).
- ▶ Push the unit upwards or downwards before lifting it from the DIN rail.

Wiring

Please note:

- ▶ Information given in the "[Technical details \[📖 20\]](#)" must be followed.
- ▶ Outputs 17-18, 27-28, 37-38 are safety contacts; output 45-46 is an auxiliary contact (e.g. for display).
- ▶ Auxiliary contact 45-46 should **not** be used for safety circuits!
- ▶ To prevent contact welding, a fuse should be connected before the output contacts (see [Technical details \[📖 20\]](#)).
- ▶ Calculation of the max. cable length l_{\max} in the input circuit:

$$l_{\max} = \frac{R_{l_{\max}}}{R_l / \text{km}}$$

$R_{l_{\max}}$ = max. overall cable resistance (see [Technical details \[📖 20\]](#))

R_l / km = cable resistance/km

- ▶ Use copper wire that can withstand 60/75 °C.
- ▶ Sufficient fuse protection must be provided on all output contacts with capacitive and inductive loads.
- ▶ Ensure the wiring and EMC requirements of EN 60204-1 are met.
- ▶ The power supply must comply with the regulations for extra low voltages with protective electrical separation (SELV, PELV) in accordance with VDE 0100, Part 410.

Preparing for operation

Operating modes and delay time

The operating mode and delay time are set via the rotary switches on the unit. You can do this by opening the cover on the front of the unit.







NOTICE

Do not adjust the rotary switch during operation, otherwise an error message will appear, the safety contacts will open and the unit will not be ready for operation until the supply voltage has been switched off and then on again.

Set operating modes

- ▶ Switch off supply voltage.
- ▶ Select operating mode via the operating mode selector switch "mode".
- ▶ If the operating mode selector switch "mode" is in its start position (vertical position), an error message will appear.

operating mode selector switch "mode"	delay-on de-energisation, not retriggerable	delay-on de-energisation, retriggerable	delay-on energisation	pulse on switching on
				

Set delay time

Time selector switch "t[s]"

Factor selector switch "n"

$n \times t[s] = \text{Delay time}$

Example:

$t = 4 \text{ s}, n = 5$

Delay time = $5 \times 4 = 20 \text{ s}$

Connection

- ▶ Supply voltage

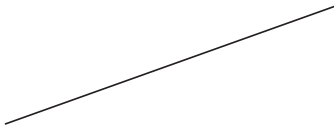
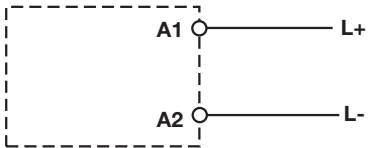
Supply voltage	AC	DC
		



INFORMATION

The supply voltage may only be connected as shown in the examples listed below!

► 1-channel input circuit/feedback loop

Input circuit	Input circuit	Feedback loop
Without base unit (stand-alone)		
Base unit: Safety relay PNOZ X		
Base unit: Safety relay PNOZelog; driven via semiconductor outputs (24 VDC)		



INFORMATION

Feedback loop

The inputs that evaluate the feedback loop will depend on the base unit and application.

* with PNOZelog as base unit:

The selectable delay-on de-energisation of PNOZ s9 may only be used with the safety relay PNOZ e1p. Other PNOZelog safety relays must be operated without delay-on de-energisation.

► 2-channel input circuit

	Base unit: Safety relays PNOZ s3, PNOZ s4, PNOZ s5	Base unit: Safety relays PNOZ s1, PNOZ s2
The input circuit is connected and evaluated via the connector.		
	Base unit: Two-hand control device PNOZ s6	Base unit: Two-hand control device PNOZ s6.1
The input circuit is connected and evaluated via the connector.		



INFORMATION

If a base unit and a contact expansion module from the PNOZsigma range are linked via the connector, no additional wiring is necessary. Do not connect S32 on the contact expansion module!

▶ Application

	Without feedback loop	With feedback loop
Without base unit		

Legend

- ▶ S3: Start button

Operation

When the relay outputs are switched on, the mechanical contact on the relay cannot be tested automatically. Depending on the operational environment, measures to detect the non-opening of switching elements may be required under some circumstances.

When the product is used in accordance with the European Machinery Directive, a check must be carried out to ensure that the safety contacts on the relay outputs open correctly. Open the safety contacts (switch off output) and start the device again, so that the internal diagnostics can check that the safety contacts open correctly

- ▶ for SIL CL 3/PL e at least 1x per month
- ▶ for SIL CL 2/PL d at least 1x per year



NOTICE

The safety function should be checked after initial commissioning and each time the plant/machine is changed. The safety functions may only be checked by qualified personnel.

The unit is ready for operation when the Power LED is permanently lit.

LEDs indicate the status and errors during operation:

- LED on
- LED flashes



INFORMATION

Status indicators and error indicators may occur independently. In the case of an error display, the "Fault" LED will light or flash (exception: "Supply voltage too low"). An LED that is also flashing indicates the potential cause of the error. An LED that is lit and is static indicates a normal operating status. Several status indicators and error indicators may occur simultaneously.

Status indicators



POWER

Supply voltage is present.



IN1

Input circuit at S32 is closed.



IN2

Input circuit at S32 is closed.



OUT

Safety contacts are closed.



RESET

24 VDC is present at S34.



OUT

Set delay time is running.

Fault indicators



FAULT

Diagnostics: Plug terminator not connected

- ▶ Remedy: Insert plug terminator, switch supply voltage off and then on again.

With base unit PNOZsigma:

Diagnostics: Input circuit S32 is closed without authorisation



FAULT

Diagnostics: Internal error, unit defective

- ▶ Remedy: Switch supply voltage off and then on again, change unit if necessary.



POWER

Diagnostics: Supply voltage too low

- ▶ Remedy: Check supply voltage and increase if necessary.



RESET FAULT

Diagnostics: Position of rotary switch is not permitted or rotary switch was adjusted during operation.

- ▶ Remedy: Switch supply voltage off and then on again.



POWER, IN1, IN2, OUT, RESET, FAULT

Diagnostics: The operating mode selector switch "mode" is in its start position (vertical position)

- ▶ Remedy: Switch off the supply voltage and set the required operating mode on operating mode selector switch "mode".

Faults - malfunctions

- ▶ Contact malfunctions: If the contacts have welded, reactivation will not be possible after the input circuit has opened.
- ▶ In the case of an error, the delay-on de-energisation contacts may open before the delay time has elapsed.

Dimensions in mm

*with spring-loaded terminals

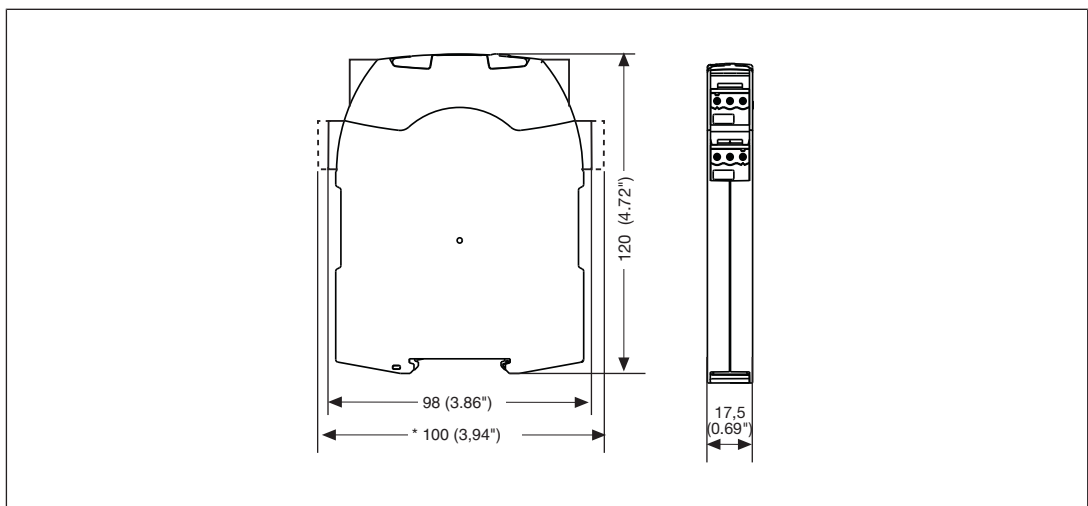

Technical details

General	750109	751109	751189
Approvals	CCC, CE, EAC (Eurasian), KOSHA, TÜV, cULus Listed	CCC, CE, EAC (Eurasian), KOSHA, TÜV, cULus Listed	CCC, CE, EAC (Eurasian), KOSHA, TÜV, cULus Listed
Electrical data	750109	751109	751189
Supply voltage			
Voltage	24 V	24 V	24 V
Kind	DC	DC	DC
Voltage tolerance	-20 %/+20 %	-20 %/+20 %	-20 %/+20 %
Output of external power supply (DC)	2 W	2 W	2 W
Residual ripple DC	20 %	20 %	20 %
Duty cycle	100 %	100 %	100 %
Max. inrush current impulse			
Current pulse, A1	0,7 A	0,7 A	0,7 A
Pulse duration, A1	10 ms	10 ms	10 ms
Max. overall cable resistance R _{lmax}			
Feedback loop	30 Ohm	30 Ohm	30 Ohm
A1/A2	20 Ohm	20 Ohm	20 Ohm
Inputs	750109	751109	751189
Voltage at			
Feedback loop DC	24 V	24 V	24 V
Current at			
Input circuit DC	15 mA	15 mA	15 mA
Feedback loop DC	15 mA	15 mA	15 mA
Max. inrush current impulse			
Current pulse, input circuit	0,1 A	0,1 A	0,1 A
Pulse duration, input circuit	20 µs	20 µs	20 µs
Current pulse, feedback loop	0,1 A	0,1 A	0,1 A
Pulse duration, feedback loop	20 µs	20 µs	20 µs
Max. overall cable resistance R _{lmax}			
Single-channel at UB DC	30 Ohm	30 Ohm	30 Ohm

Relay outputs	750109	751109	751189
Number of output contacts			
Safety contacts (N/O), delayed	3	3	3
Auxiliary contacts (N/C), delayed	1	1	1
Max. short circuit current IK	1 kA	1 kA	1 kA
Utilisation category			
In accordance with the standard	EN 60947-4-1	EN 60947-4-1	EN 60947-4-1
Utilisation category of safety contacts			
AC1 at	240 V	240 V	240 V
Min. current	0,01 A	0,01 A	0,01 A
Max. current	6 A	6 A	6 A
Max. power	1500 VA	1500 VA	1500 VA
DC1 at	24 V	24 V	24 V
Min. current	0,01 A	0,01 A	0,01 A
Max. current	6 A	6 A	6 A
Max. power	150 W	150 W	150 W
Utilisation category of auxiliary contacts			
AC1 at	240 V	240 V	240 V
Min. current	0,01 A	0,01 A	0,01 A
Max. current	6 A	6 A	6 A
Max. power	1500 VA	1500 VA	1500 VA
DC1 at	24 V	24 V	24 V
Min. current	0,01 A	0,01 A	0,01 A
Max. current	6 A	6 A	6 A
Max. power	150 W	150 W	150 W
Utilisation category			
In accordance with the standard	EN 60947-5-1	EN 60947-5-1	EN 60947-5-1
Utilisation category of safety contacts			
AC15 at	230 V	230 V	230 V
Max. current	5 A	5 A	5 A
DC13 (6 cycles/min) at	24 V	24 V	24 V
Max. current	5 A	5 A	5 A
Utilisation category of auxiliary contacts			
AC15 at	230 V	230 V	230 V
Max. current	5 A	5 A	5 A
DC13 (6 cycles/min) at	24 V	24 V	24 V
Max. current	5 A	5 A	5 A

Relay outputs	750109	751109	751189
Utilisation category in accordance with UL			
Voltage	240 V AC G.U. (same polarity)	240 V AC G.U. (same polarity)	240 V AC G.U. (same polarity)
With current	6 A	6 A	6 A
Voltage	24 V DC G. U.	24 V DC G. U.	24 V DC G. U.
With current	6 A	6 A	6 A
External contact fuse protection, safety contacts			
In accordance with the standard	EN 60947-5-1	EN 60947-5-1	EN 60947-5-1
Max. melting integral	260 A²s	260 A²s	260 A²s
Blow-out fuse, quick	10 A	10 A	10 A
Blow-out fuse, slow	6 A	6 A	6 A
Blow-out fuse, gG	10 A	10 A	10 A
Circuit breaker 24V AC/DC, characteristic B/C	6 A	6 A	6 A
External contact fuse protection, auxiliary contacts			
Max. melting integral	160 A²s	160 A²s	160 A²s
Blow-out fuse, quick	10 A	10 A	10 A
Blow-out fuse, slow	6 A	6 A	6 A
Blow-out fuse, gG	6 A	6 A	6 A
Circuit breaker 24 V AC/DC, characteristic B/C	6 A	6 A	6 A
Conventional thermal current			
	6 A	6 A	6 A
Contact material	AgCuNi + 0,2 µm Au	AgCuNi + 0,2 µm Au	AgCuNi + 0,2 µm Au
Times	750109	751109	751189
Switch-on delay			
With manual start typ.	60 ms	60 ms	60 ms
With manual start max.	80 ms	80 ms	80 ms
Delay-on de-energisation			
With E-STOP typ.	40 ms	40 ms	40 ms
With E-STOP max.	50 ms	50 ms	50 ms
Recovery time at max. switching frequency 1/s			
After power failure	800 ms	800 ms	800 ms

Times	750109	751109	751189
Delay time tv	0,04 s, 0,1 s, 0,2 s, 0,3 s, 0,4 s, 0,5 s, 0,6 s, 0,7 s, 0,8 s, 1 s, 1,5 s, 2 s, 2,5 s, 3 s, 3,5 s, 4 s, 5 s, 6 s, 7 s, 8 s, 10 s, 12 s, 14 s, 15 s, 16 s, 20 s, 25 s, 30 s, 35 s, 40 s, 50 s, 60 s, 70 s, 80 s, 90 s, 100 s, 120 s, 140 s, 150 s, 160 s, 180 s, 200 s, 210 s, 240 s, 300 s	0,04 s, 0,1 s, 0,2 s, 0,3 s, 0,4 s, 0,5 s, 0,6 s, 0,7 s, 0,8 s, 1 s, 1,5 s, 2 s, 2,5 s, 3 s, 3,5 s, 4 s, 5 s, 6 s, 7 s, 8 s, 10 s, 12 s, 14 s, 15 s, 16 s, 20 s, 25 s, 30 s, 35 s, 40 s, 50 s, 60 s, 70 s, 80 s, 90 s, 100 s, 120 s, 140 s, 150 s, 160 s, 180 s, 200 s, 210 s, 240 s, 300 s	0,04 s, 0,1 s, 0,2 s, 0,3 s, 0,4 s, 0,5 s, 0,6 s, 0,7 s, 0,8 s, 1 s, 1,5 s, 2 s, 2,5 s, 3 s, 3,5 s, 4 s, 5 s, 6 s, 7 s, 8 s, 10 s, 12 s, 14 s, 15 s, 16 s, 20 s, 25 s, 30 s, 35 s, 40 s, 50 s, 60 s, 70 s, 80 s, 90 s, 100 s, 120 s, 140 s, 150 s, 160 s, 180 s, 200 s, 210 s, 240 s, 300 s
Time accuracy	+/-1 % + +/-20 ms	+/-1 % + +/-20 ms	+/-1 % + +/-20 ms
Repetition accuracy	+/-1 % + +/-20 ms	+/-1 % + +/-20 ms	+/-1 % + +/-20 ms
Repetition accuracy in the event of an error	+/-15 % + +/-20 ms	+/-15 % + +/-20 ms	+/-15 % + +/-20 ms
Min. delay time (operating mode delay-on energisation)	tv - 15 % - 20 ms	tv - 15 % - 20 ms	tv - 15 % - 20 ms
Max. delay time	tv + 15 % + 20 ms	tv + 15 % + 20 ms	tv + 15 % + 20 ms
Supply interruption before de-energisation in the input circuit	10 ms	10 ms	10 ms
Supply interruption before de-energisation	10 ms	10 ms	10 ms
Environmental data	750109	751109	751189
Climatic suitability	EN 60068-2-78	EN 60068-2-78	EN 60068-2-78
Ambient temperature			
Temperature range	-15 - 55 °C	-15 - 55 °C	-15 - 55 °C
Storage temperature			
Temperature range	-40 - 85 °C	-40 - 85 °C	-40 - 85 °C
Climatic suitability			
Humidity	93 % r. h. at 40 °C	93 % r. h. at 40 °C	93 % r. h. at 40 °C
Condensation during operation	Not permitted	Not permitted	Not permitted
EMC	EN 60947-5-1, EN 61000-6-2, EN 61000-6-4, EN 61326-3-1	EN 60947-5-1, EN 61000-6-2, EN 61000-6-4, EN 61326-3-1	EN 60947-5-1, EN 61000-6-2, EN 61000-6-4, EN 61326-3-1
Vibration			
In accordance with the standard	EN 60068-2-6	EN 60068-2-6	EN 60068-2-6
Frequency	10 - 55 Hz	10 - 55 Hz	10 - 55 Hz
Amplitude	0,35 mm	0,35 mm	0,35 mm
Airgap creepage			
In accordance with the standard	EN 60947-1	EN 60947-1	EN 60947-1
Overvoltage category	III	III	III
Pollution degree	2	2	2
Rated insulation voltage	250 V	250 V	250 V

Environmental data	750109	751109	751189
Rated impulse withstand voltage	6 kV	6 kV	6 kV
Protection type			
Housing	IP40	IP40	IP40
Terminals	IP20	IP20	IP20
Mounting area (e.g. control cabinet)	IP54	IP54	IP54
Mechanical data	750109	751109	751189
Mounting position	Any	Any	Any
Mechanical life	10,000,000 cycles	10,000,000 cycles	10,000,000 cycles
Material			
Bottom	PC	PC	PC
Front	PC	PC	PC
Top	PC	PC	PC
Connection type	Screw terminal	Spring-loaded terminal	Spring-loaded terminal
Mounting type	plug-in	plug-in	plug-in
Conductor cross section with screw terminals			
1 core flexible	0,25 - 2,5 mm², 24 - 12 AWG	–	–
2 core with the same cross section, flexible with crimp connectors, no plastic sleeve	0,25 - 1 mm², 24 - 16 AWG	–	–
2 core with the same cross section, flexible without crimp connectors or with TWIN crimp connectors	0,2 - 1,5 mm², 24 - 16 AWG	–	–
Torque setting with screw terminals	0,5 Nm	–	–
Conductor cross section with spring-loaded terminals: Flexible with/without crimp connector	–	0,2 - 2,5 mm², 24 - 12 AWG	0,2 - 2,5 mm², 24 - 12 AWG
Spring-loaded terminals: Terminal points per connection	–	2	2
Stripping length with spring-loaded terminals	–	9 mm	9 mm
Dimensions			
Height	98 mm	100 mm	100 mm
Width	17,5 mm	17,5 mm	17,5 mm
Depth	120 mm	120 mm	120 mm
Weight	175 g	175 g	175 g

Where standards are undated, the 2017-01 latest editions shall apply.

Safety characteristic data



NOTICE

You must comply with the safety-related characteristic data in order to achieve the required safety level for your plant/machine.

Operating Mode	EN ISO 13849-1: 2015 PL	EN ISO 13849-1: 2015 Category	EN 62061 SIL CL	EN 62061 PFH _D [1/h]	IEC 61511 SIL	IEC 61511 PFD	EN ISO 13849-1: 2015 T _M [year]
----------------	----------------------------	----------------------------------	--------------------	------------------------------------	------------------	------------------	---

Safety con-
tacts,
delayed

PL e	Cat. 4	SIL CL 3	2,34E-09	SIL 3	2,75E-05	20
-------------	---------------	-----------------	-----------------	--------------	-----------------	-----------

All the units used within a safety function must be considered when calculating the safety characteristic data.



INFORMATION

A safety function's SIL/PL values are **not** identical to the SIL/PL values of the units that are used and may be different. We recommend that you use the PAscal software tool to calculate the safety function's SIL/PL values.

Supplementary data



CAUTION!

It is essential to consider the relay's service life graphs. The relay outputs' safety-related characteristic data is only valid if the values in the service life graphs are met.

The PFH value depends on the switching frequency and the load on the relay output. If the service life graphs are not accessible, the stated PFH value can be used irrespective of the switching frequency and the load, as the PFH value already considers the relay's B10d value as well as the failure rates of the other components.

Service life graph

The service life graphs indicate the number of cycles from which failures due to wear must be expected. The wear is mainly caused by the electrical load; the mechanical load is negligible.

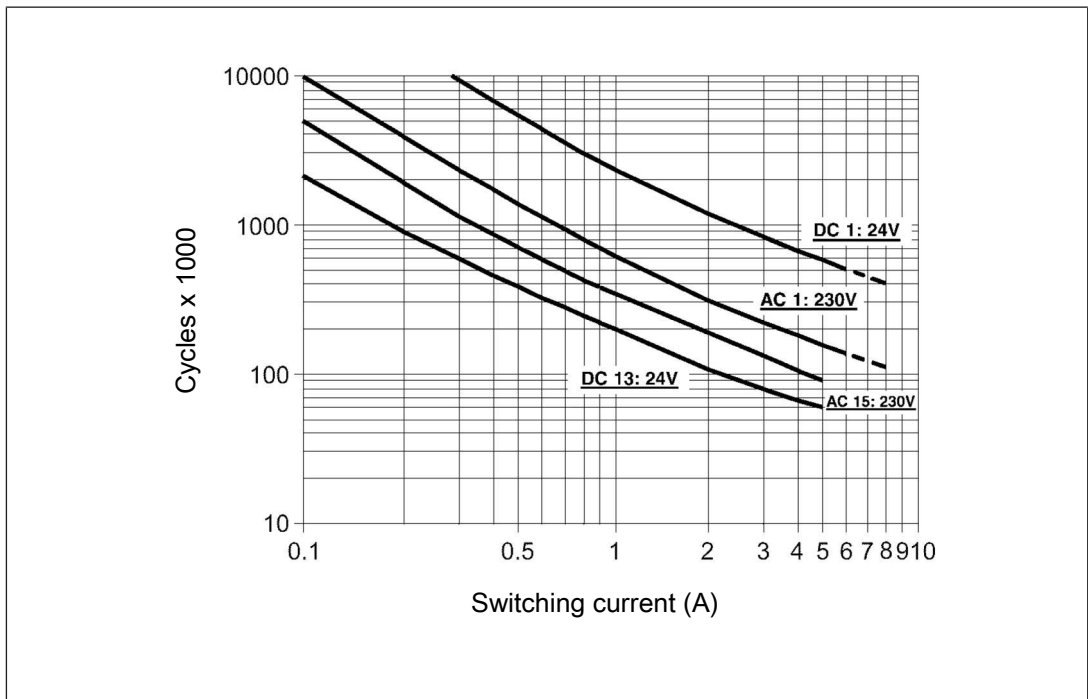

Fig.: Service life graphs at 24 V DC and 230 V AC

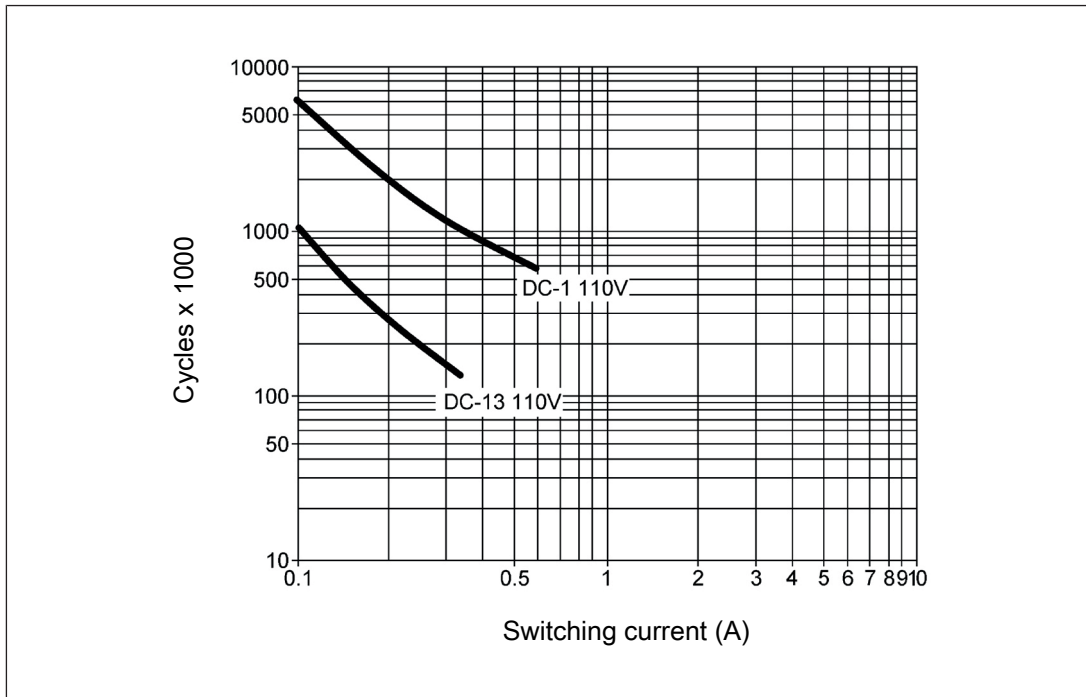

Fig.: Service life graphs at 110 V DC

Example

- ▶ Inductive load: 0.2 A
- ▶ Utilisation category: AC15
- ▶ Contact service life: 2 000 000 cycles

Provided the application to be implemented requires fewer than 2 000 000 cycles, the PFH value (see [Technical details \[📖 20\]](#)) can be used in the calculation.

To increase the service life, sufficient spark suppression must be provided on all output contacts. With capacitive loads, any power surges that occur must be noted. With DC contactors, use flywheel diodes for spark suppression.

Permitted operating height

The values stated in the technical details apply to the use of the device in operating heights up to max. 2000 m above sea level. When used in greater heights, constraints have to be taken into account:

- ▶ Permitted maximum operating height 5000 m
- ▶ Reduction of rated insulation voltage and rated impulse withstand voltage for applications with safe separation:

Maximum operation height	Rated insulation voltage	Overvoltage category	Max. rated impulse withstand voltage
3000 m	150 V	II	2.5 kV
	100 V	III	2.5 kV
4000 m	150 V	II	2.5 kV
	100 V	III	2.5 kV
5000 m	150 V	II	2.5 kV
	100 V	III	2.5 kV

- ▶ Reduction of rated insulation voltage and rated impulse withstand voltage for applications with basic insulation:

Maximum operation height	Rated insulation voltage	Overvoltage category	Max. rated impulse withstand voltage
3000 m	250 V	II	2.5 kV
	150 V	III	2.5 kV
4000 m	250 V	II	2.5 kV
	150 V	III	2.5 kV
5000 m	250 V	II	2.5 kV
	150 V	III	2.5 kV

- ▶ From an operating height of 2000 m the max. permitted ambient temperature is reduced by 0.5 °C/100 m

Operating height	Permitted ambient temperature
3000 m	50 °C
4000 m	45 °C
5000 m	40 °C

Remove plug-in terminals

Procedure: Insert the screwdriver into the housing recess behind the terminal and lever the terminal out.

Do **not** remove the terminals by pulling the cables!

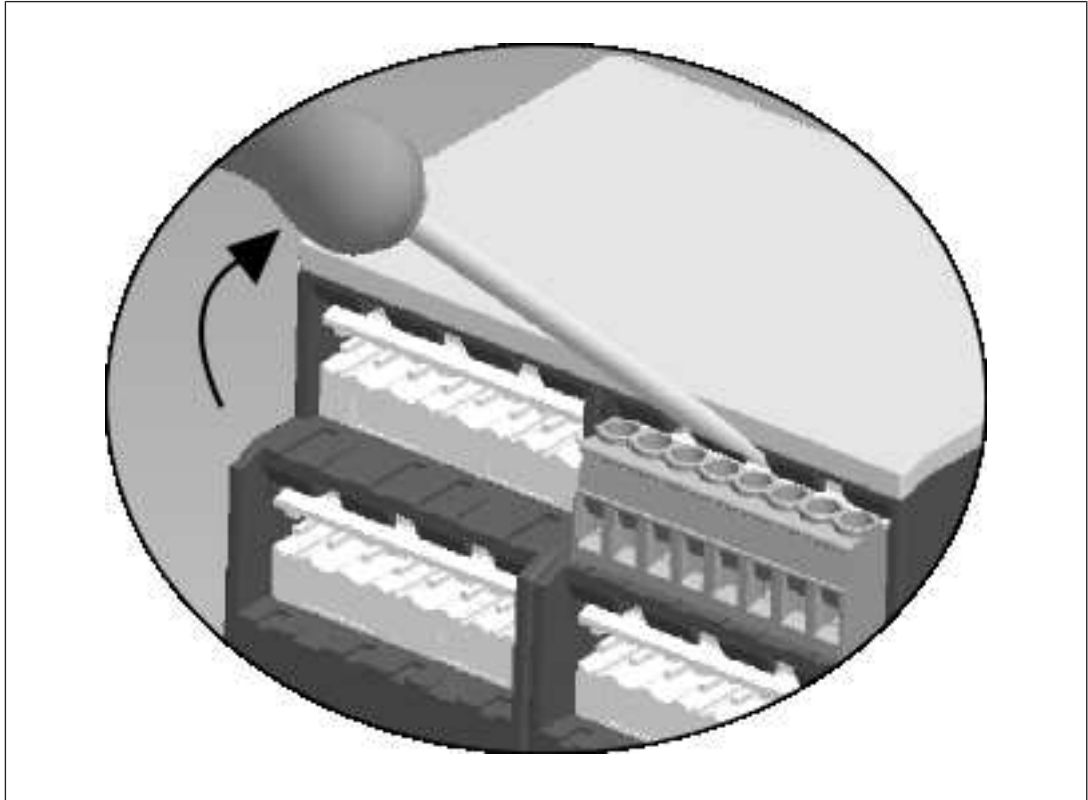

Order reference

Product type	Features	Connection type	Order No.
PNOZ s9	24 VDC	Screw terminals	750 109
PNOZ s9 C	24 VDC	Spring-loaded terminals	751 109
PNOZ s9 C (coated version)	24 VDC	Spring-loaded terminals	751 189
PNOZ s9 C	24 VDC; 10 pieces	Spring-loaded terminals	751 909

EC declaration of conformity

This product/these products meet the requirements of the directive 2006/42/EC for machinery of the European Parliament and of the Council. The complete EC Declaration of Conformity is available on the Internet at www.pilz.com/downloads.

Representative: Norbert Fröhlich, Pilz GmbH & Co. KG, Felix-Wankel-Str. 2, 73760 Ostfildern, Germany